



---

# INSTALLATION MANUAL

---

## Paper Tray Lock System

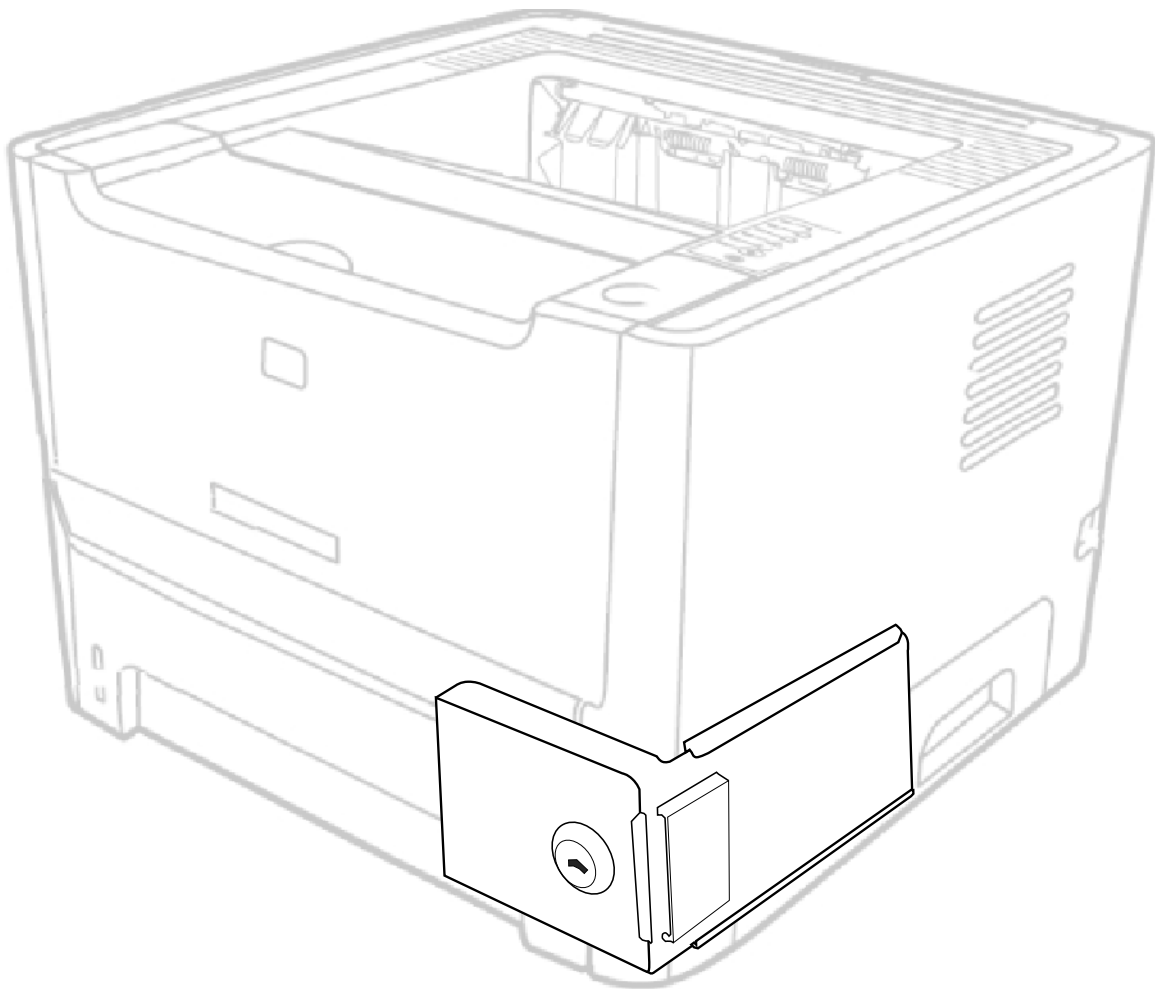

**Lucas Distribution, LLC**  
**PO Box 1754**  
**Loganville, Georgia 30052-1754**



## Table of Contents

Contact Lucas Distribution, LLC .....	3
Parts List .....	4
Installation .....	5 & 6
Installation for Uneven Surfaces.....	7

## Lucas Distribution, LLC

### Contact Information

Customer Service - (866) 232-4233

Technical Support - [sales@papertraylock.com](mailto:sales@papertraylock.com)

Website - [www.papertraylock.com](http://www.papertraylock.com)

If calling from outside the U.S. please dial 770-554-3560

# Paper Tray Lock System



## Parts List

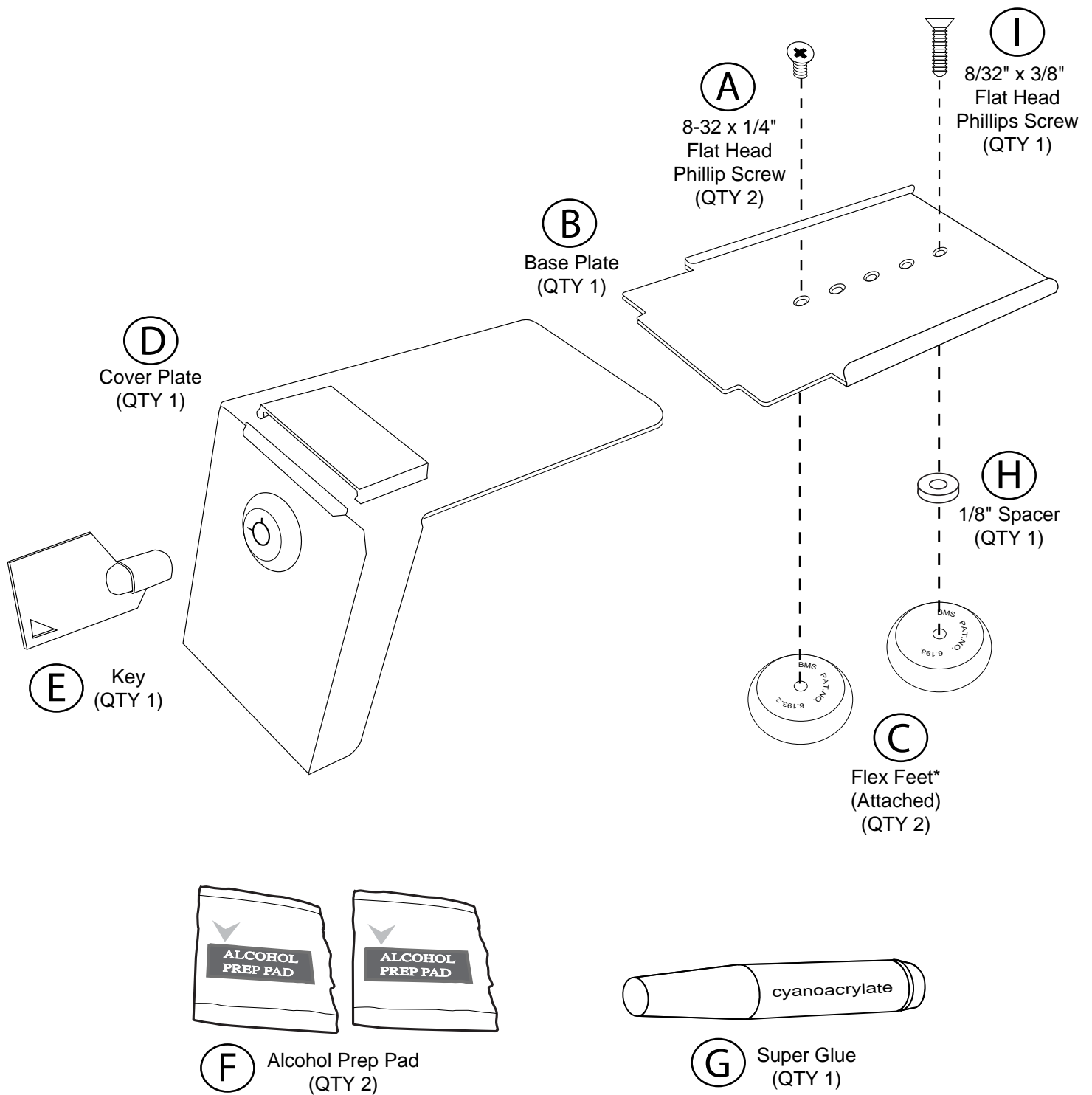

## INSTALLATION

**\*\*\*We highly recommend you visit our website at [www.papertraylock.com](http://www.papertraylock.com) and watch our short installation video\*\*\***

1. Place the Paper Tray Lock (PTL) in various positions on the printer to determine the best area for installation. Check that the Flex Feet lie flat against the surface and do not block any openings, vents or moving parts. (Figure 1)
2. If the base plate does not lie flat and make full contact with the mounting surface refer to instructions on page 7.
3. Once placement is determined, with a pencil trace around the PTL to mark the installation area. (Figure 2)
4. Using the provided alcohol swabs (F), thoroughly clean inside the marked area on the printer as well as the Flex Feet (C) located on the base plate (B) making sure that NO dust or debris remain. \*\*It is very important that the bonding surfaces be completely cleaned and air dried in order to achieve the best possible bond. (Figure 3)
5. Position the PTL so the Flex Feet on the base plate are facing up then open the container of glue (G) and place a single drop in each of the embossed circles. \*\*Using too much glue can cause it to exceed the surface area of the Flex Feet (C) and may result in runs, drips or build up. (Figure 4)

Figure 1

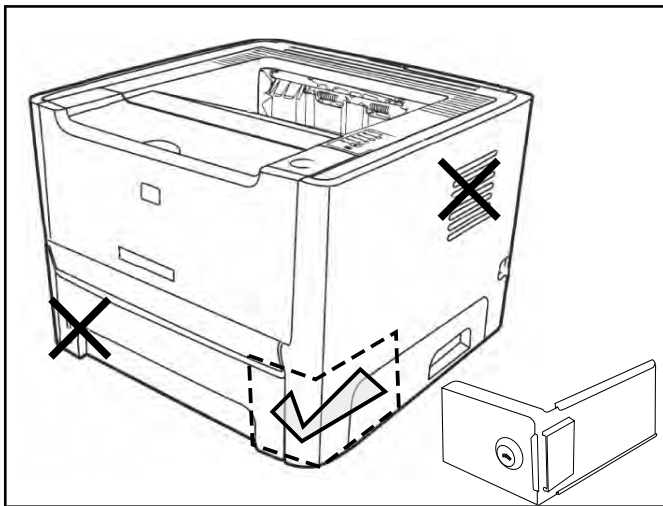

Figure 2

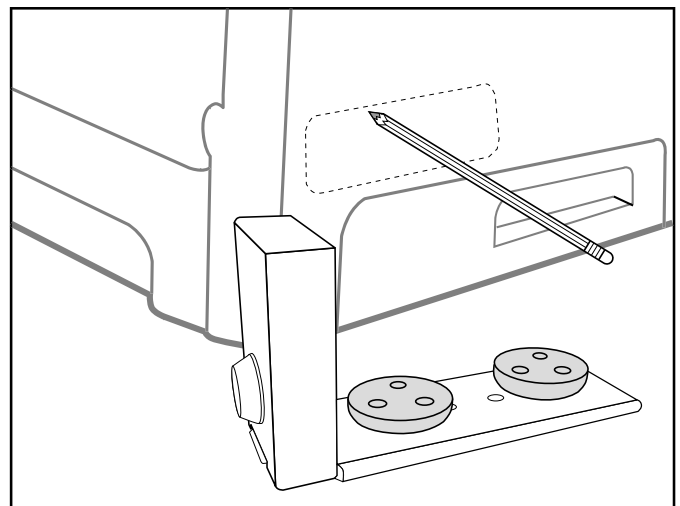

Figure 3

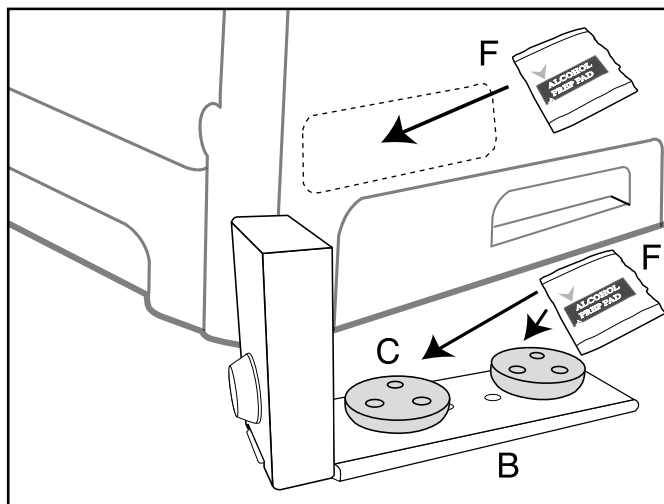
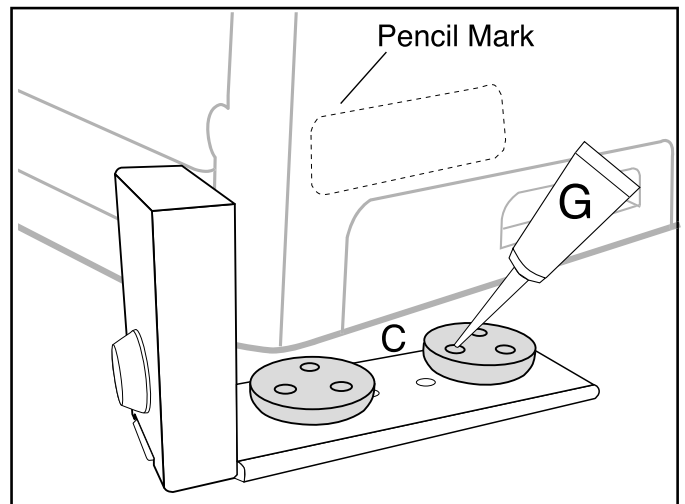

Figure 4



## INSTALLATION

6. Quickly and carefully place the PTL in the marked area and firmly apply pressure from the center out for NO LESS THAN 100 seconds (it is recommended that you count out loud to ensure that the proper time has elapsed) making sure that no air enters the bonded area. \*\*It is important that no air enters the area otherwise the bond will be compromised over time. (Figure 5)

7. Once you've counted to 100 unlock and remove the Cover Plate (D) from the Base Plate (B) and allow the glue to cure for 24 HOURS. In order to ensure a strong, permanent bond it is important to not place any weight on the Base Plate (B) for 24 hours, until the bond is fully cured. (Figure 6 & 7)

8. Once the bond is cured, slide the Cover Plate (D) onto the Base Plate (B) and turn the key (E) to lock. (Figure 8)

Figure 5

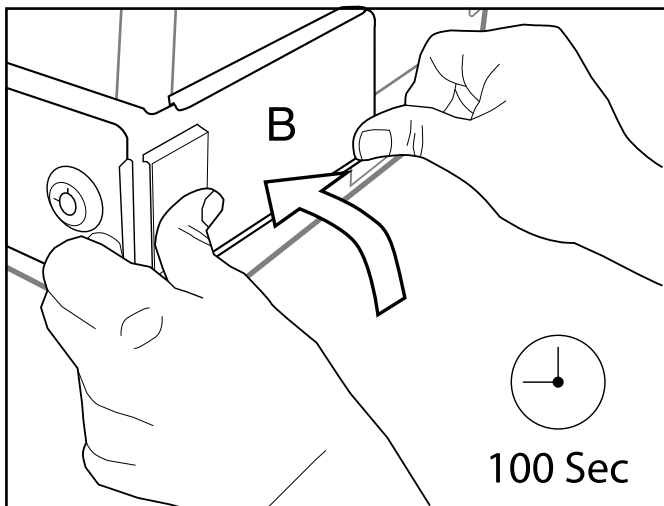

Figure 6

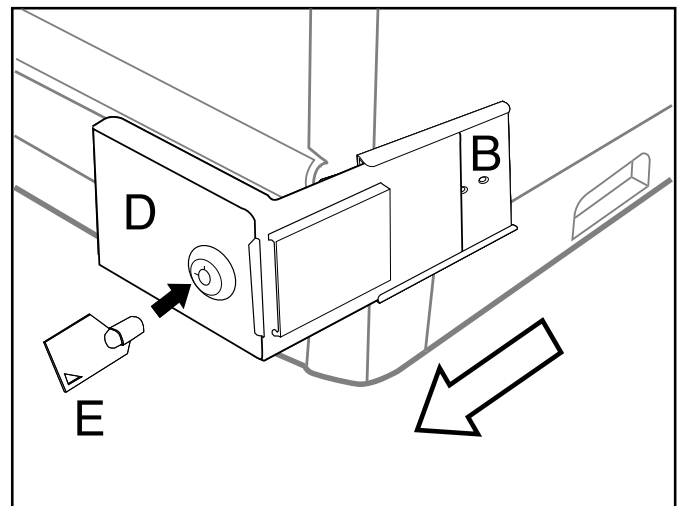

Figure 7

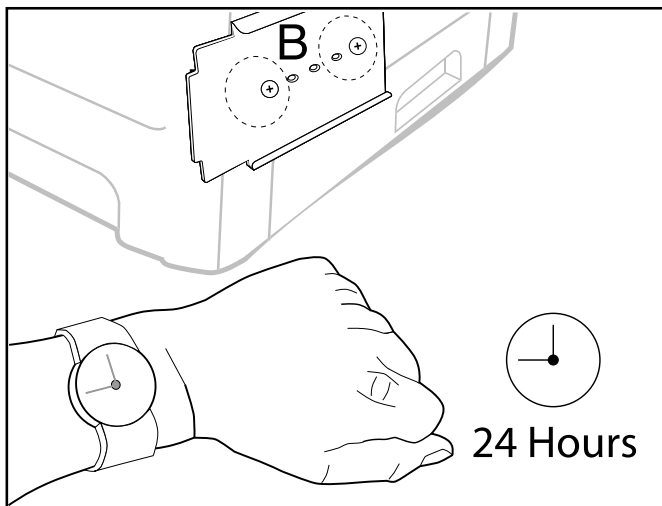
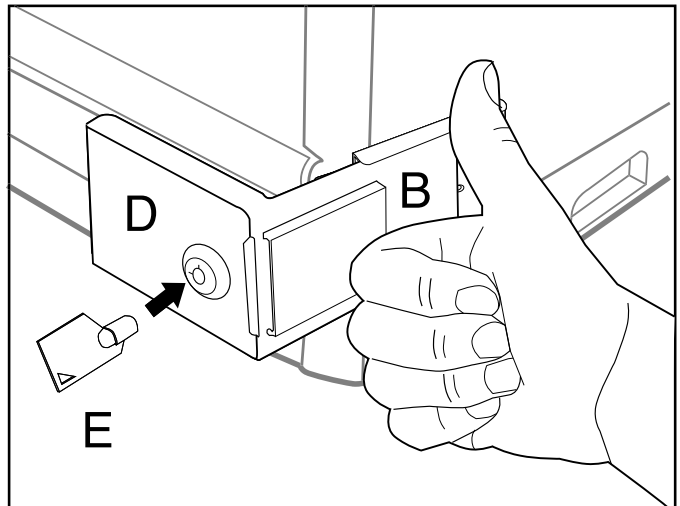

Figure 8



## INSTALLATION FOR UNEVEN SURFACES

1. When the PTL must be attached to an uneven surface it is possible that the two Flex Feet (C) will not lie flat against the surface. (Figure 9 & 10)
2. If a Flex Foot (C) is overlapping two uneven surfaces, mark where the Flex Foot (C) must be trimmed and cut off the unnecessary area of the Flex Foot (C). (Figure 11)
3. If no area of the Flex Foot (C) contacts the mounting surface, place a spacer (H) in between the Base Plate (B) and the Flex Foot (C) and use the Large Screw (I) to secure the Flex Foot (C) to the Base Plate (B) (this can be used in any hole). (Figure 12)
4. Once you have made the necessary changes to the Flex Feet (C) assemble and lock the PTL, place in position on the printer and confirm the Flex Feet lie flat against the surface of the printer. (Figure 13 & 14)
5. After the position has been confirmed continue with Step 3 on page 5 for the rest of the installation.

\* NOTE: Spacer can be used on either front or back Flex Foot depending on your need.

\*\* NOTE: Flex Feet will adhere to curved surfaces as long as proper pressure is applied.

Figure 9

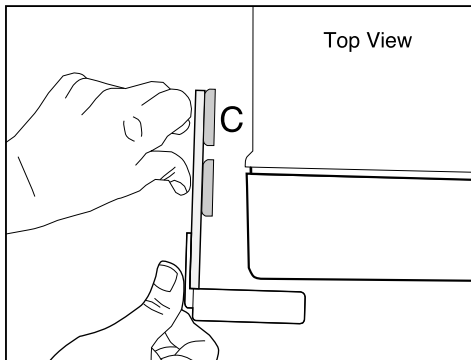

Figure 10

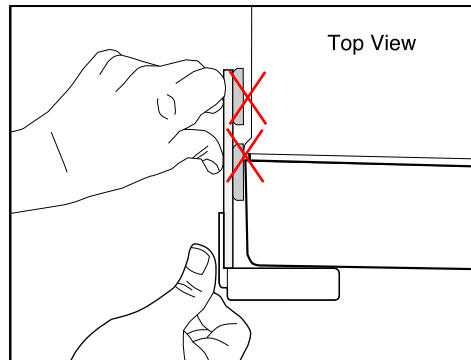

Figure 11

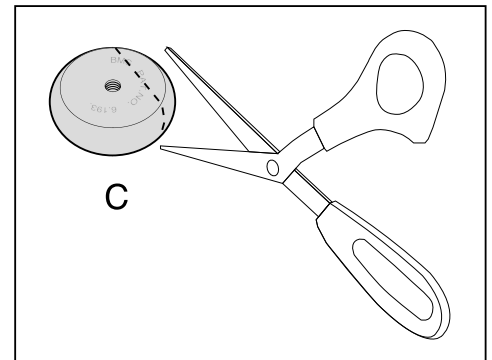

Figure 12

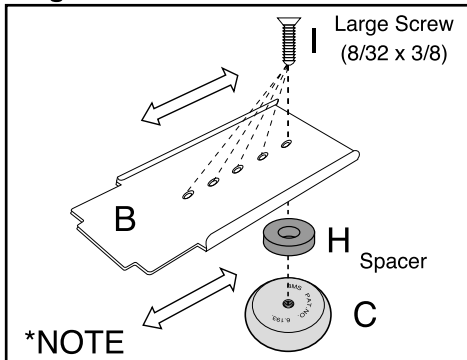

Figure 13

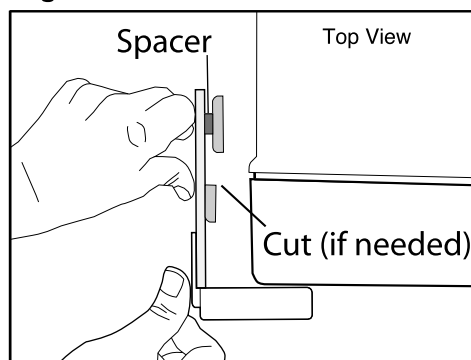

Figure 14

